

# RCA2-TA6R

ROBO Cylinder Table Type Side-Mounted Motor 65mm Width 24V Servo Motor Ball Screw

■ Configuration: **RCA2** — **TA6R** — **I** — **20** —  —  —  —  —

Series — Type — Encoder — Motor — Lead — Stroke — Compatible Controllers — Cable Length — Option

I: Incremental  
\* The simple absolute encoder is also considered type "I".

20: 20W Servo motor

Lead: 12: 12mm  
6: 6mm  
3: 3mm

Stroke: 25: 25mm  
150: 150mm (25mm pitch increments)

Compatible Controllers: A1: ACON, RACON, ASEL, A3: AMEC, ASEP

Cable Length: N: None, P: 1m, S: 3m, M: 5m, X  : Custom

Option: See Options below  
\* Be sure to specify which side the motor is to be mounted (ML/MR).

\* See page Pre-35 for an explanation of the naming convention.

**Power-saving**



**Technical References** P. A-5

**POINT** Notes on Selection

- Please note that the maximum speed is different when used horizontally versus vertically.
- The load capacity is based on operation at an acceleration of 0.3G (0.2G for the 3mm-lead model, or when used vertically). This is the upper limit of the acceleration.

**Actuator Specifications**

■ Lead and Load Capacity

Model	Motor Output (W)	Lead (mm)	Max. Load Capacity		Rated Thrust (N)	Stroke (mm)
			Horizontal (kg)	Vertical (kg)		
RCA2-TA6R-I-20-12-①-②-③-④	20	12	2	0.5	17	25~150 (25mm increments)
RCA2-TA6R-I-20-6-①-②-③-④		6	4	1.5	34	
RCA2-TA6R-I-20-3-①-②-③-④		3	6	3	68	

Legend: ① Stroke ② Compatible controller ③ Cable length ④ Options

■ Stroke and Maximum Speed

Lead	Stroke	
	25 ~ 150 (25mm increments)	560 <500>
12	560 <500>	
6	300	
3	150	

\* The values enclosed in '<' >' apply to vertical usage. (Unit: mm/s)

① Stroke List

Stroke (mm)	Standard Price
25	-
50	-
75	-
100	-
125	-
150	-

③ Cable List

Type	Cable Symbol	Standard Price
Standard Type (Robot Cables)	P (1m)	-
	S (3m)	-
	M (5m)	-
Special Lengths	X06 (6m) ~ X10 (10m)	-
	X11 (11m) ~ X15 (15m)	-
	X16 (16m) ~ X20 (20m)	-
		-

\* The standard cable is the motor-encoder integrated robot cable.  
\* See page A-39 for cables for maintenance.

④ Option List

Name	Option Code	See Page	Standard Price
Brake	B	→ A-25	-
Cable exit direction (Top)	CJT	→ A-25	-
Cable exit direction (Outside)	CJO		
Cable exit direction (Bottom)	CJB		
Power-saving	LA	→ A-32	-
Left-mounted Motor (Standard)	ML	→ A-33	-
Right-mounted motor	MR	→ A-33	-
Reversed-home	NM	→ A-33	-

**Actuator Specifications**

Item	Description
Drive System	Ball screw ø10mm C10 grade
Positioning Repeatability	±0.02mm
Lost Motion	0.1mm or less
Base	Material: Aluminum (special alumite treated)
Allowable Static Load Moment	Ma: 29.4 N·m Mb: 42.0 N·m Mc: 74.1 N·m
Allowable Dynamic Load Moment	Ma: 7.26 N·m Mb: 10.3 N·m Mc: 18.25 N·m
Overhang Load Length	Within the load moment range
Ambient Operating Temp./Humidity	0~40°C, 85% RH or less (non-condensing)

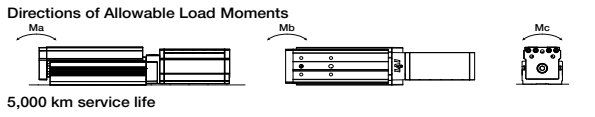

**313** RCA2-TA6R

- Slider Type
- Mini
- Standard
- Controllers Integrated
- Rod Type
- Mini
- Standard
- Controllers Integrated
- Table/Arm /Flat Type
- Mini
- Standard
- Gripper/ Rotary Type
- Linear Servo Type
- Cleanroom Type
- Splash Proof
- Controllers
- PMEC /AMEC
- PSEP /ASEP
- ROBO NET
- ERC2
- PCON
- ACON
- SCON
- PSEL
- ASEL
- SSEL
- XSEL
- Pulse Motor
- Servo Motor (24V)
- Servo Motor (200V)
- Linear Servo Motor

Dimensions

For Special Orders P. A-9

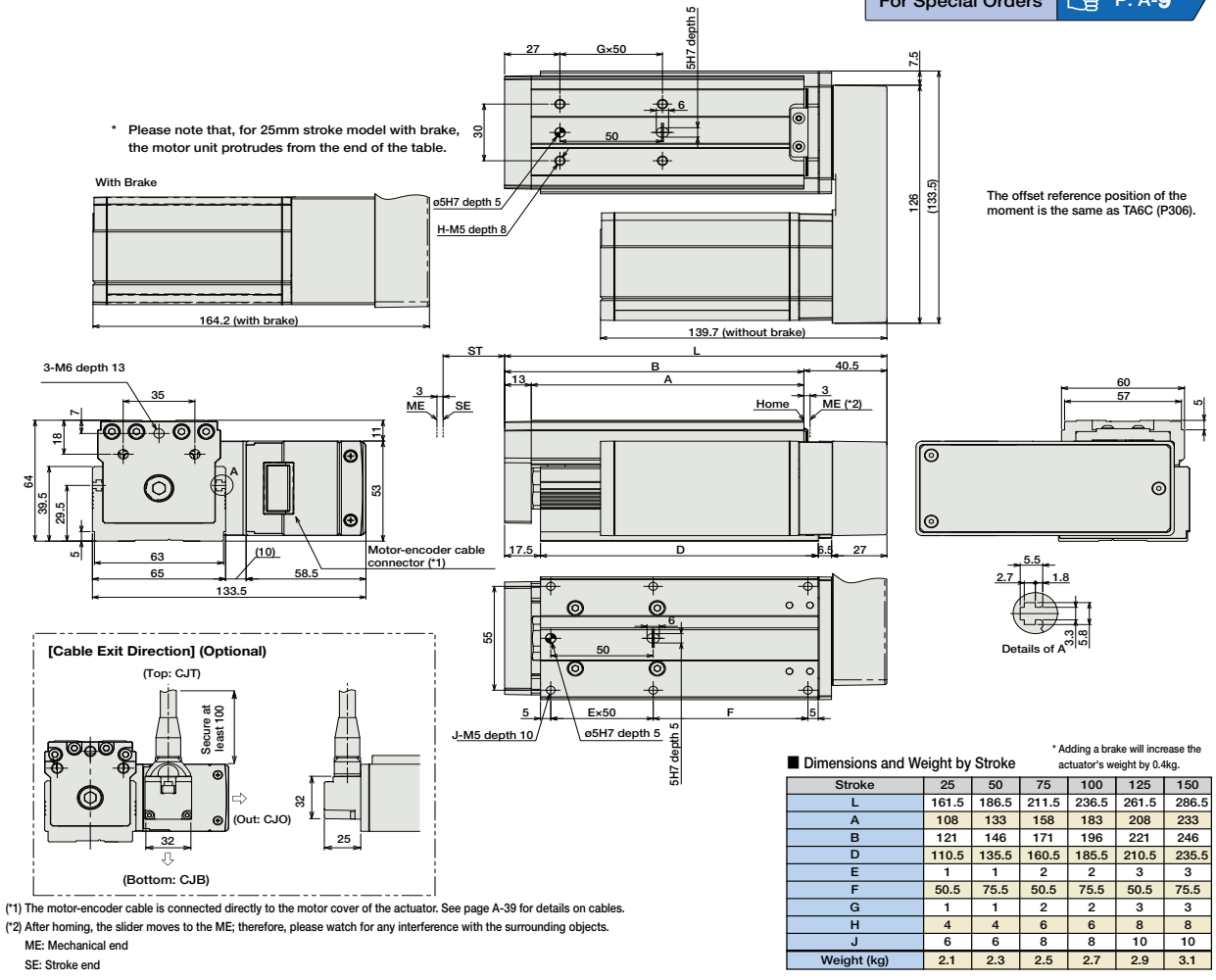

(\*1) The motor-encoder cable is connected directly to the motor cover of the actuator. See page A-39 for details on cables.  
 (\*2) After homing, the slider moves to the ME; therefore, please watch for any interference with the surrounding objects.  
 ME: Mechanical end  
 SE: Stroke end

② Compatible Controllers

The RCA2 series actuators can operate with the controllers below. Select the controller according to your usage.

Name	External View	Model	Description	Max. Positioning Points	Input Voltage	Power Supply Capacity	Standard Price	See Page
Solenoid Valve Type		AMEC-C-20i①-NP-2-1	Easy-to-use controller, even for beginners	3 points	AC100V	2.4A rated	-	→ P477
		ASEP-C-20i①-NP-2-0	Operable with same signal as solenoid valve. Supports both single and double solenoid types. No homing necessary with simple absolute type.					→ P487
Splash-Proof Solenoid Valve Type		ASEP-CW-20i①-NP-2-0						
Positioner Type		ACON-C-20i①-NP-2-0	Positioning is possible for up to 512 points	512 points	DC24V	(Standard) 1.3A rated 4.4A max.	-	
Safety-Compliant Positioner Type		ACON-CG-20i①-NP-2-0						
Pulse Train Input Type (Differential Line Driver)		ACON-PL-20i①-NP-2-0	Pulse train input type with differential line driver support	(-)	DC24V	(Power-saving) 1.3A rated 2.5A max.	-	→ P535
Pulse Train Input Type (Open Collector)		ACON-PO-20i①-NP-2-0	Pulse train input type with open collector support					
Serial Communication Type		ACON-SE-20i①-N-0-0	Dedicated to serial communication	64 points				
Field Network Type		RACON-20①	Dedicated to field network	768 points				→ P503
Program Control Type		ASEL-C-1-20i①-NP-2-0	Programmed operation is possible. Operation is possible on up to 2 axes	1500 points				→ P567

\* This is for the single-axis ASEL.  
 \* ① is a placeholder for the code "LA", if the power-saving option is specified.

- Slider Type
- Mini
- Standard
- Controllers Integrated
- Rod Type
- Mini
- Standard
- Controllers Integrated
- Table/Arm /Flat Type
- Mini
- Standard
- Gripper/ Rotary Type
- Linear Servo Type
- Cleanroom Type
- Splash Proof
- Controllers
- PMEC /AMEC
- PSEP /ASEP
- ROBO NET
- ERC2
- PCON
- ACON
- SCON
- PSEL
- ASEL
- SSEL
- XSEL
- Pulse Motor
- Servo Motor (24V)
- Servo Motor (200V)
- Linear Servo Motor



RCA2-TA6R **314**